

STA-RITE®

SYSTEM 3 HIGH RATE SAND FILTERS

O W N E R ' S M A N U A L

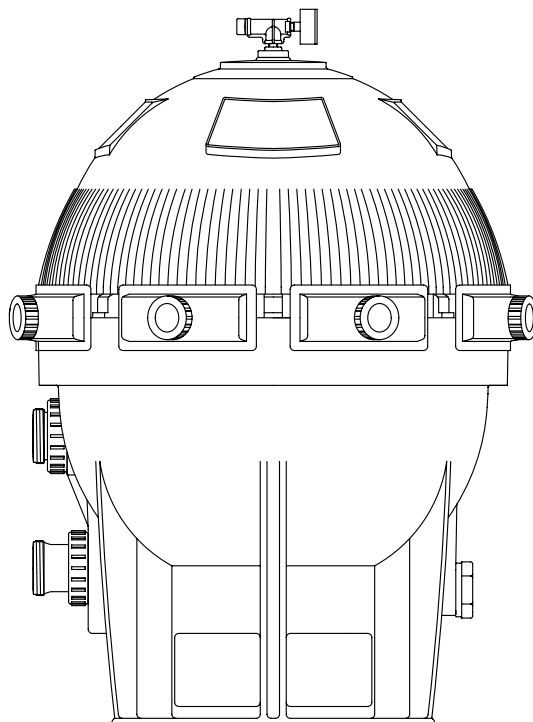

INSTALLATION, OPERATION & PARTS

MODELS

S7S50

S8S70



This manual should be furnished to the end user of this filter; its use will reduce service calls and chance of injury and will lengthen filter life.

Sta-Rite Pool/Spa Group

293 Wright Street, Delavan, WI 53115

International: 262-728-5551, FAX: 262-728-7550

www.starite.com

Union City, TN • Delavan, WI • Mississauga, Ont. • Murrieta, CA

© 2004, Sta-Rite Industries

Printed in U.S.A.

S282 (Rev. 4/20/04)

HIGH RATE SAND FILTERS

To avoid unneeded service calls, prevent possible injuries, and get the most out of your filter, READ THIS MANUAL CAREFULLY!

The Sta-Rite System 3 High Rate Sand Filter:

- Is designed to filter water for swimming pools.
- Is an excellent performer; durable, reliable.

Table of Contents

Safety Instructions.....	2-3
General Information/Specifications	4
Installation	5
Initial Filling.....	6
Filter Disassembly/Assembly.....	6-7
Startup/Operation	7
Backwash	8
Maintenance.....	8-9
Replace Internal Assembly	9
Winterizing.....	9
Repair Parts List	10-11
Troubleshooting Guide.....	12
Warranty.....	15

READ AND FOLLOW SAFETY INSTRUCTIONS!



 **DANGER**

 **WARNING**

 **CAUTION**

This is the safety-alert symbol. When you see this symbol on your valve or in this manual, look for one of the following signal words and be alert to the potential for personal injury.

DANGER warns about hazards that **will** cause serious personal injury, death or major property damage if ignored.

WARNING warns about hazards that **can** cause serious personal injury, death or major property damage if ignored.

CAUTION warns about hazards that **will** or **can** cause minor personal injury or property damage if ignored.

The label **NOTICE** indicates special instructions which are important but not related to hazards.

Carefully read and follow all safety instructions in this manual and on filter.

Keep safety labels in good condition.
Replace missing or damaged safety labels.



Incorrectly installed or tested equipment may fail, causing severe injury or property damage. Read and follow instructions in owner's manual when installing and operating equipment. Have a trained pool professional perform all pressure tests.

1. Do not connect system to a high pressure or city water system.
2. Use equipment only in a pool or spa installation.
3. Trapped air in system can cause explosion. BE SURE all air is out of system before operating or testing equipment.

Before pressure testing, make the following safety checks:

- Check all clamps, bolts, lids, and system accessories before testing.
- Release all air in system before testing.
- Tighten Sta-Rite pump trap lids to 30 ft. lbs. (4.1 kg-cm) torque for testing.
- Water pressure for test must be less than 25 PSI (172 kPa).
- Water temperature for test must be less than 100° F. (38° C).
- Limit test to 24 hours. After test, visually check system to be sure it is ready for operation. Remove pump trap lid and retighten hand tight only.

NOTICE: These parameters apply to Sta-Rite equipment only. For non Sta-Rite equipment, consult manufacturer.

	<p>⚠ DANGER</p> <p>If filter clamp is adjusted under pressure, tank will blow off of base, causing severe injury or major property damage.</p>	<p>BEFORE WORKING ON FILTER:</p> <ol style="list-style-type: none"> 1. Stop pump. 2. Open air release valve. 3. Release all pressure from system.
	<p>⚠ WARNING</p> <p>Filter pumps require hazardous voltage which can shock, burn, or cause death</p>	<p>BEFORE WORKING ON PUMP OR MOTOR</p> <p>Disconnect power to motor.</p>

⚠ WARNING

Hazardous pressure. Can cause severe injury or major property damage from tank blow up.

Release all pressure and read instructions before working on filter.

GENERAL INFORMATION

- Clean a new pool as well as possible before filling pool and operating filter. Excess dirt and large particles of foreign matter in the system can cause serious damage to the filter and pump.
- ⚠ **Do not operate filter at water temperatures above 120°F (65.5°C).**
- ⚠ **NEVER operate this filter system at more than 50 pounds per square inch (50 PSI/345kPa) pressure!**

TABLE I - OUTLINE DIMENSIONS IN INCHES (mm)

Sand Model	A	B	C No. of Clamps	D	E	F
S7S50	28-1/2(724)	42(1067)	7	36(914)	53-1/2(1360)	2" NPT
S8S70	32-1/2(825)	42-1/4(1073)	8	40(1020)	54-1/4(1380)	2" NPT

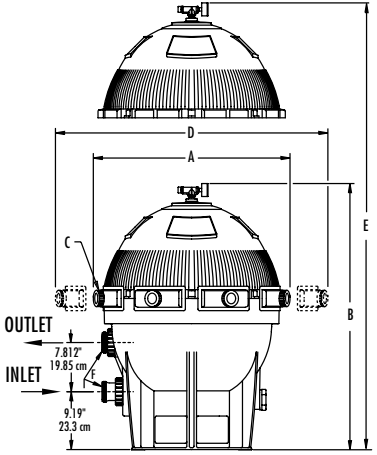

Figure 1 - Dimensions

TABLE II - FILTER SPECIFICATIONS AND OPERATING INFORMATION

FILTER MODEL:	S7S50	S8S70
Filter Area	2.4 Ft. ² (.223M ²)	3.4 Ft. ² (.316M ²)
Flow Rate Range	33-48 GPM(125-182 L/m)	47-68 GPM(178-257 L/m)
Public Pool Flow Rate	48 GPM(182 L/m)	68 GPM(257 L/m)
Max. Operating Pressure	50 PSI(345 kPa)	50 PSI(345 kPa)
Freeboard (See Fig. 1B)*	11" (28 cm)	11" (28 cm)
Turnover in Hours:		
6 Hours	17,200 Gal.(65 102 liters)	24,400 Gal.(92 354 liters)
8 Hours	23,000 Gal.(87 055 liters)	32,600 Gal.(123 391 liters)
10 Hours	28,800 Gal.(109 008 liters)	40,800 Gal.(154 428 liters)
Qty. of Media Required:		
Cu. Ft.	2(56 540cm ³)	3(84 960cm ³)
Weight (Pounds)	200(90,7 kg)	300(136 kg)

* Freeboard is the open space between the top of the sand bed and the tank backwash outlet.

NOTICE: 1 cubic foot (28 320 cm³) of sand weighs approximately 100 lbs. (45,4kg). DO NOT use a finer grade of sand than recommended.

RECOMMENDED SAND GRADES:

Use only: #20 Silica Sand, Size Range .40-.55mm., Uniformity Coefficient less than 1.75.

NOTICE: Use of other sands will reduce filter performance, may damage pump, and will void warranty.

Recommended:

1. Wedron Silica/Best Sand Co., Sand Grade: Wedron .45-.55mm., Effective Size .46mm, Uniformity Coefficient 1.22.
2. U.S. Silica - Silurian Filter Sand, Sand Grade.45-.55 mm., Effective Size .48mm, Uniformity Coefficient 1.18.

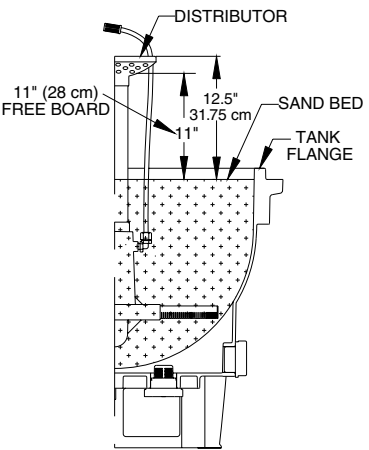
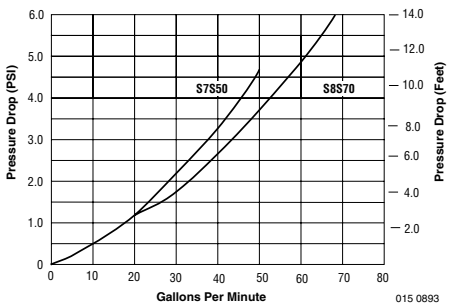

Figure 2 - Freeboard measurement



INSTALLATION

Installation of filter should only be done by qualified, licensed personnel. For assembly and filling instructions, see pages 6 and 7.

Filter mount must:

- Provide weather and freezing protection.
- Provide space and lighting for easy access for routine maintenance. (See Figure I and Table 1, Page 4, for space requirements.)
- Be on a reasonably level surface and provide adequate drainage.
- Be as close to pool as possible to reduce line loss from pipe friction.

Piping:

- Piping must conform to local/state plumbing and sanitary codes.
- Use pipe joint sealing compound or Teflon tape on all male connections of metal pipe and fittings (except unions). Use Teflon tape or Plasto-Joint Stik¹ on all male connections of plastic pipe and fittings. **DO NOT use pipe dope on plastic pipe; it will cause stress cracking of the pipe. Do not use sealant or tape on unions – assemble them dry and hand tight.**
- Do not damage union sealing surfaces and O-Rings.
- Support pipe independently to prevent strains on filter or valve.
- Use 2" pipe to reduce pressure losses as much as possible.

NOTICE: Filter may be located away from pool, but for adequate flow larger pipe may be needed. For more information about hydraulic design, call Sta-Rite Customer Service.

- Fittings restrict flow; for best efficiency use fewest possible fittings.
- Keep piping tight and free of leaks: pump suction line leaks may cause trapped air in filter tank or loss of prime at pump; pump discharge line leaks may show up as dampness or jets of water.
- **NOTICE:** Overtightening can crack filter ports.

Valves:

- A check valve installed ahead of filter inlet will prevent contaminants from draining back into pool.
- A check valve installed between filter and heater will prevent hot water from backing up into filter and deforming internal components.
- Install Sta-Rite Two Position Slide Valve or Multiport Selector Valve with filter. See Table III.
- Filter ports and valve ports are furnished with union connections.
DO NOT use pipe sealants on union collar (nut).
- Use care before assembly not to damage union sealing surfaces or O-Ring.

Wastewater:

- Be sure all provisions for waste water disposal meet applicable local, state or national codes. 100 gallons (379 liters) or more of pool water will be discharged during filter backwashing. Do not discharge where water will cause flooding or damage.

Assembly:

See Pages 6 and 7 for assembly filling instructions.

TABLE III - Sta-Rite valves for use with filters

Port Size	Part Number
2"	Multi-port WC212-144P
1-1/2"	WC212-143P
2"	Brass Slide WC212-136D
2"	Plastic Slide WC212-134P

NOTICE: Use of valves other than those listed above could cause reversed water flow through filters and damage to internal filter components.

¹ Lake Chemical Co., Chicago, IL

⚠ CAUTION

⚠ WARNING



**Hazardous pressure.
Can cause severe injury or major property damage from tank blow up.**

Release all pressure and read instructions before working on filter.

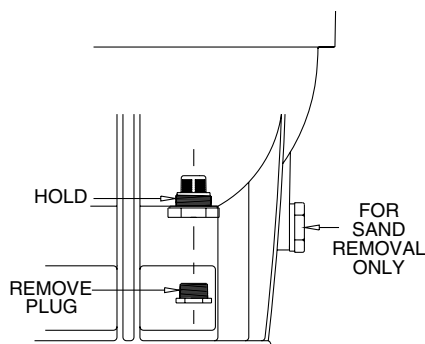

Figure 3 - Hold drain fitting and remove drain plug to drain filter.

FILTER DISASSEMBLY/ASSEMBLY

- ⚠** To avoid equipment damage and personal injury, never change handle position on control valve while pump is running.

BEFORE DISASSEMBLING FILTER:

- ⚠** 1. STOP PUMP.
2. OPEN air release valve and drain fitting.
3. WAIT until all pressure is released and water drained from filter tank and system before loosening clamp knobs.

Disassembly:

1. Backwash filter according to instructions under "Filter Backwash Procedure", Page 8 (when first filling a new filter, omit this step).
2. Stop pump.
3. Open air release valve (Key No.1, Page 10) on top of filter tank to release all air pressure from inside of tank and system.
4. Remove filter drain plug (Key No. 17B, Page 10) and drain all water from tank (see Figure 3). Hold drain fitting securely in filter body to avoid losing sand.
5. To equalize flange stresses, loosen clamp knobs alternately (that is, on opposite sides of tank) around tank. Remove clamps.
6. Being careful not to damage Cord Ring (Key No.12, Page 10), lift upper tank shell (Key No. 7, Page 10) off lower tank shell (Key No. 14, Page 10).

Filling Filter with Sand:

1. See Page 4 for correct sand grade and quantity.
2. Before pouring sand into filter, look inside and check internal assembly (Key No. 8, Page 10) for broken or loose laterals (Key No. 8A, Page 10) caused by shipping damage. Replace if necessary.
3. To eliminate stress on laterals (Key No. 8A) fill tank half-full of water before loading sand.
4. When full, top of sand bed should be about 12-1/2" (31.75 cm) below top of distributor (about 1-1/2" (3.8 cm) below tank flange (see Figure 2).
5. Wash all sand and dirt away from cord ring sealing area.
6. Assemble filter according to instructions, pages 6 and 7.

Assembly:

1. Remove cord ring slowly to avoid stretching or tearing it.
2. Inspect cord ring (Key No. 12, Page 10) for cuts, nicks, etc. If cord ring is damaged, deformed, or has lost its resiliency, replace with a new one.
3. Clean cord ring area of tank shell (both halves) and cord ring.
4. Carefully install cord ring and upper tank shell (Key No. 7, Page 10).

NOTICE: Do not lubricate cord ring. Lubricants attract dirt and grit and may (especially when petroleum based) damage cord ring and void warranty.

NOTICE: Be sure upper tank shell contacts cord ring surface evenly and seal area is clean and free from dirt.

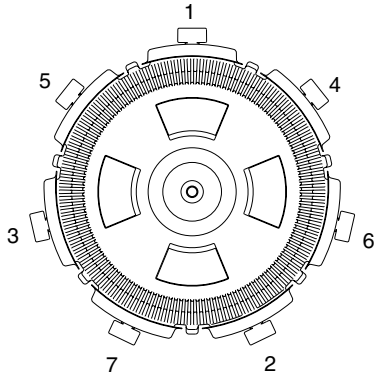

21" Filter

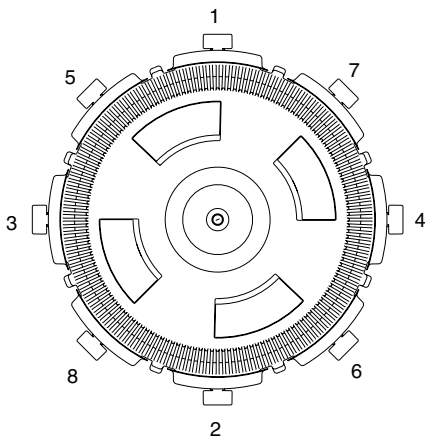

25" Filter

Figure 4 - Clamp tightening sequence.

5. Install clamps. Do not tighten clamps yet.
6. See Figure 4 for clamp tightening sequence. Tighten all clamp knobs securely hand tight.

NOTICE: To equalize stresses on tank, be sure to tighten clamps in sequence shown. DO NOT work your way around the filter tightening adjacent clamps.

7. Install air relief valve and gauge assembly on tank.

Startup (Multi-port Valve):

1. With pump OFF, set valve to 'BACKWASH' position.
2. Open air release valve (Key No. 1, Page 10).
3. Start pump, circulating water backwards through filter to waste.
4. Close air release valve when a steady stream of water is expelled.
5. Run pump five minutes or until waste water is clear (this purges excess fine particles from system).
6. Stop pump; set valve handle to 'RINSE' position.
7. Start pump; run pump for 15 to 30 seconds.
8. Stop pump; set valve to 'FILTER' position. Follow instructions under 'Regular Operation' (below) to place filter in service.

Startup (Slide Valve):

1. With pump OFF, raise handle to fully extended position.
2. Open air release valve (Key No. 1, Page 10).
3. Start pump, circulating water backwards through filter to waste.
4. Close air release valve when a steady stream of water is expelled.
5. Run pump five minutes or until waste water is clear (this purges excess fine particles from system).
6. Stop pump; lower handle completely to 'FILTER' position and pin in place. Follow instructions under 'Regular Operation' (below) to place filter in service.

REGULAR OPERATION

▲WARNING Do not operate this filter at more than 50 PSI (345kPa) under any circumstances!

Run Filter:

1. With pump OFF, set valve to 'FILTER' position.
2. Fill trap on pump with water.
3. Open air release valve on top of filter assembly (Key No. 1, Page 10); start pump.
4. When steady stream of water comes from air release valve, close the valve.
5. With filter operating, record pressure gauge reading in owner's manual. When reading is 10 PSI (70kPa) above initial reading, backwash filter.

CAUTION

Backwash Filter (Multi-Port Valve):

 To prevent equipment damage and possible injury, turn pump OFF before changing valve position.

1. With pump OFF, set valve to 'BACKWASH' position.
2. Open air release valve (Key No. 1, Page 10).
3. Start pump, circulating water backwards through filter to waste.
4. Close air release valve when a steady stream of water is expelled.
5. Backwash until water runs clear.
6. Stop pump; set valve to 'RINSE' position.
7. Start pump; run pump for one minute.
8. Stop pump; set valve to 'FILTER' position.
9. Filter is now ready for service.
10. Open air release valve and release ALL pressure from system.
11. Follow 'Run filter' procedure to restart system.

Backwash Filter (Slide Valve):

 To prevent equipment damage and possible injury, turn pump OFF before changing valve position.

1. With pump OFF, raise valve handle to fully extended position.
2. Open air release valve (Key No. 1, Page 10).
3. Start pump, circulating water backwards through filter to waste.
4. Close air release valve when a steady stream of water is expelled.
5. Backwash until water runs clear.
6. Stop pump; lower handle completely to 'FILTER' position and pin in place.
7. Filter is now ready for service.
8. Open air release valve and release ALL pressure from tank and system.
9. Follow 'Run filter' procedure (above) to restart system.

MAINTENANCE

General:

- Wash outside of filter with a mild detergent and water. Rinse off with hose.
NOTICE: DO NOT use solvents to clean filter; solvents may damage plastic components in system.
- Inspect sand bed at least once a year to remove foreign material which has not been backwashed out of system.

 **WARNING** Follow instructions on Pages 6 and 7 when disassembling and assembling filter.

NOTICE: When the sand bed gets hard and crusty on top, remove all the old sand and replace it with new sand.

NOTICE: Open air bleed valve and bleed all air from filter each time pump is stopped and restarted.

Weekly Pool Equipment Inspection:

1. Check pressure during operation. When pressure is 10 PSI (70kPa) higher than initial operating pressure, backwash filter (see instructions, page 7).

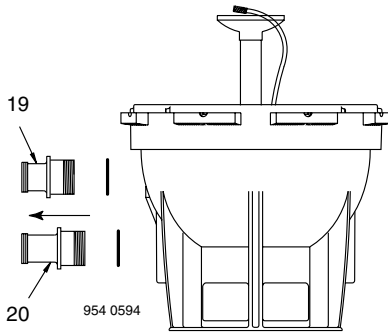

Figure 5

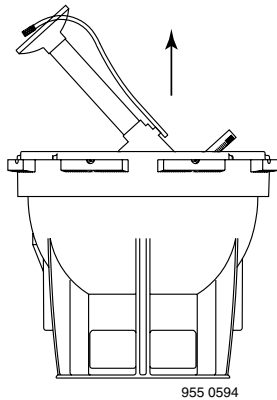

Figure 6

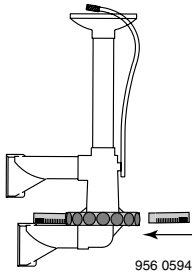

Figure 7

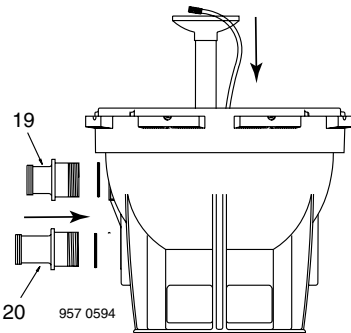

Figure 8

2. Skimmer basket - remove debris.
3. Stop pump, release all pressure from system. Remove trap cover and basket, remove debris.
4. Bleed air from filter each time system is started.
5. Check pump for leaks. If found, see pump owner's manual.
6. Check pump strainer lid for tightness. Do not overtighten!

Replace Internal Assembly:

1. Disassemble filter according to instructions in "Filter Disassembly" Page 6.

⚠ WARNING Hazardous Pressure! To avoid severe injury and major property damage, follow instructions on Pages 6 and 7 when disassembling and assembling filter.

2. Remove sand from filter.
3. Remove union adapters and tank fittings, (Key Nos. 19 and 20, Figure 5). Turn Key Nos. 19 and 20 counterclockwise to remove.
4. Lift old internal assembly out of tank. (Figure 6)
5. Twist lock new laterals into hub on new internal assembly. (Figure 7)
6. Remove old O-Rings on tank fittings (Key Nos. 19 and 20) and install new O-Rings provided. Be sure sealing area is clean.
7. Drop new internal assembly into tank and secure with tank fittings (Key Nos. 19 and 20, Figure 8).
8. To refill, reassemble, and restart filter, follow instructions in owner's manual.

⚠ WARNING To avoid severe injury or major property damage, exactly follow "Assembly" instructions, Pages 6 and 7.

9. Follow "Startup" instructions in owner's manual.

WINTERIZING

1. Open air release valve; open all system valves. Position multiport valve between port positions to allow air passage to all ports.
2. Remove drain plugs from trap, pump, valve and filter.
3. Drain system piping.
4. Cover with plastic or tarpaulin to protect from weather.
5. Protect from freezing.

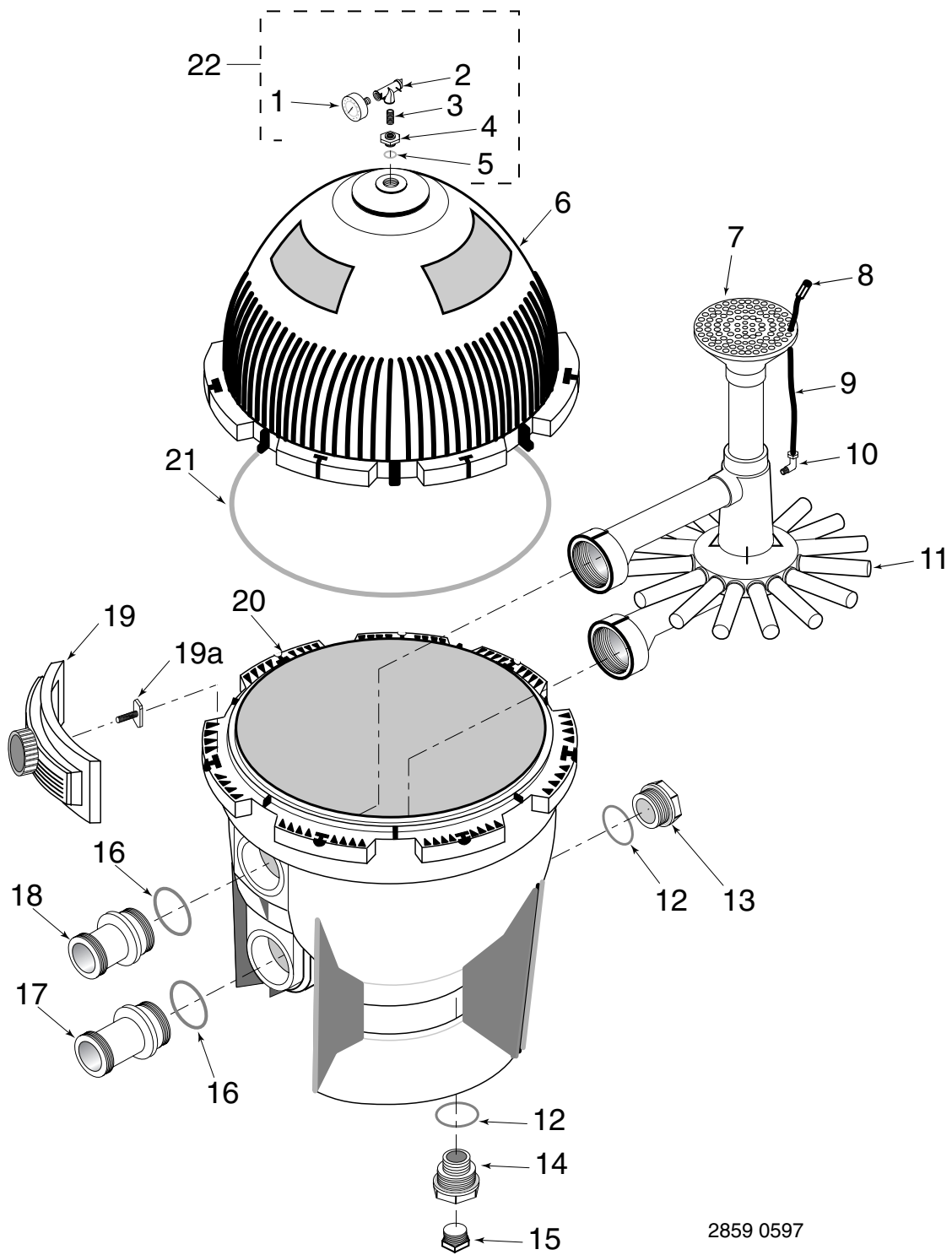

2859 0597

REPAIR PARTS LIST

Key No.	Description	Qty.	Model S7S50	Model S8S70
1	2" Gauge	1	33600-0023	33600-0023
2	Valve Assembly	1	WC212-120P	WC212-120P
3	Nipple	1	U37-16P	U37-16P
4	Adapter Bushing	1	24900-0504	24900-0504
5	O-Ring	1	35505-1423	35505-1423
6	Tank - Upper Half Kit*	1	24851-9000	24851-9001
7	Collector - Manifold Assem.	1	24900-0100	24901-0100
8	Air Bleed Filter	1	WC8-126	WC8-126
9	Vent Tube	1	WC37-386P	WC37-386P
10	Elbow - Male Parflex	1	WC78-84P	WC78-84P
11	Lateral	16	24900-0002	24900-0003
12	O-Ring	2	35505-1424	35505-1424
13	Plug (Sand Removal)	1	24900-0503	24900-0503
14	Drain Fitting	1	24900-0505	24900-0505
15	1-1/2" NPT Plug	1	27001-0022S	27001-0022S
16	O-Ring	2	35505-1425	35505-1425
17	Tank Fitting	1	24900-0500	24900-0500
18	Tank Fitting	1	24900-0501	24900-0501
19	Clamp Assembly	**	24850-0101	24850-0101
19A	Clamp Bolt	**	24850-0010	24850-0010
20	Tank - Lower Half	1	24850-0102	24851-0103
21	Cord Ring	1	24850-0008	24850-0009
22	Valve and Gauge Assembly (Includes Key Nos. 1-5)		24850-0105	24850-0105
†•	Lateral Extension Adapter	as req'd	24700-0029	24700-0029
•	Decal - Model Label	1	32155-4045	32155-4047
•	Decal - Warning	1	32165-4004	32165-4005
•	Decal - Operating Instruction	1	32155-4046	32155-4048

† Available for lateral repairs.

• Not illustrated

* Includes all decals and labels.

** Model S7S50 uses seven clamps and bolts; Model S8S70 uses eight.

TROUBLESHOOTING GUIDE

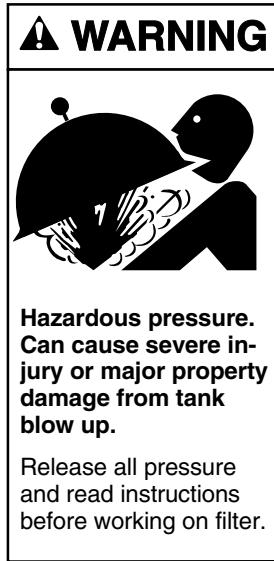

1. Short Cycle between backwashes:

NOTICE: Time between backwashes will vary with each installation and between different areas of the country. Ask installer about normal backwash interval in your area. The following causes and remedies are for cycle times shorter than normal for your area.

- A. Flow rate too high or filter too small; consult dealer for system sizing recommendations.
- B. Water is chemically out of balance; consult pool serviceman.

2. Low Flow/High Pressure:

- A. Pipe blocked downstream from filter; remove obstruction.
- B. Piping too small; use larger pipe (consult dealer for sizing).
- C. Filter area too small or pump too large; consult dealer for recommendation.

3. Low Flow/Low Pressure:

- A. Pump too small; consult dealer for recommendations.
- B. Plugged pump, plugged line, or plugged hair and lint trap; clean thoroughly.

4. Pool Water Not Clear:

- A. Water is chemically out of balance; consult pool professional.
- B. Inadequate turnover rate; consult dealer about equipment sizing.
- C. Sand in pool means broken lateral.

⚠ WARNING To avoid severe injury or major property damage, follow instructions under 'Disassembly' and 'Assembly' (pages 6 and 7)!

1. Follow filter disassembly procedure, Page 6.
2. Replace lateral according to instructions supplied with new lateral (See Page 9).
3. Reassemble filter according to instructions, Pages 6 and 7.

STA-RITE LIMITED WARRANTY

Pumps, filters, skimmers, underwater lights (except bulbs), accessories and fittings manufactured by Sta-Rite are warranted to be free of defects in material and workmanship for one (1) year from date of installation.

* Full warranty coverage is in effect for one year after installation. The pro-rated warranty covers the *tank only* during the 2nd through 10th year after installation. The amount covered decreases by 10% each year. (ie., 2nd year 90% covered, 3rd year 80% covered, etc.).

Product specific warranties:	Year from date of installation
<i>HRPB, DEPB, System 3, and PL - Tanks</i>	10 years
Internal filter components and valves	1 year
<i>Max-E-Therm - Pool/Spa Heaters</i>	2 years
Heater Enclosure only (Upper RH & LH; lower enclosure; and control board enclosure)... .	10 years
<i>Automatic Pool Cleaners including Hose</i>	2 years
<i>Cristal-Flo filters - Tanks</i>	10 years pro-rated*
Valve and internal components.	1 year
<i>Posi-Flo II - Tanks</i>	10 years
Elements	1 year
<i>PRC Cartridge -</i>	
Filter Tanks	5 years pro-rated (1st 2 years full)
Elements	1 year
<i>System 2 Above Ground Systems - Tanks</i>	10 years
Pumps / Platform and Internals	1 year
<i>Pumps</i>	1 year
When equipped with A.O. Smith 2-compartment motors (Does not include pumps sold as part of a systems package)	2 years
<i>Traps / In-Line Strainers</i>	1 year
<i>Vertical Commercial Filter - Tanks</i>	10 years
Internals	1 year
<i>Horizontal Commercial Filter</i>	
Tanks	5 years
(Years 6-9, Prorated declining 20%/year, Yr. 10 - 10%)	
Internals	1 year

The foregoing warranties relate to the original consumer purchaser ("Purchaser") only. Sta-Rite shall have the option to repair or replace the defective product, at its sole discretion. Purchasers must pay all labor and shipping charges necessary to replace the product covered by this warranty. Requests for warranty service must be made through the installing dealer. This warranty shall not apply to any product that has been subject to negligence, misapplication, improper installation or maintenance, or other circumstances which are not in Sta-Rite's direct control.

This warranty sets forth Sta-Rite's sole obligation and Purchaser's exclusive remedy for defective products.

STA-RITE SHALL NOT BE LIABLE FOR ANY CONSEQUENTIAL, INCIDENTAL OR CONTINGENT DAMAGES WHATSOEVER.

THE FOREGOING WARRANTIES ARE EXCLUSIVE AND IN LIEU OF ALL OTHER EXPRESS WARRANTIES. IMPLIED WARRANTIES, INCLUDING BUT NOT LIMITED TO THE IMPLIED WARRANTIES OF MERCHANTABILITY AND FITNESS FOR A PARTICULAR PURPOSE, SHALL NOT EXTEND BEYOND THE DURATION OF THE APPLICABLE EXPRESS WARRANTIES PROVIDED HEREIN.

Some states do not allow the exclusion or limitation of incidental or consequential damages or limitations on how long an implied warranty lasts, so the above limitations or exclusion may not apply to you. This warranty gives you specific legal rights and you may also have other rights which vary from state to state.

Supersedes all previous publications.

**Sta-Rite Industries,
293 Wright St., Delavan, WI 53115**

▲ Retain Warranty Certificate (upper portion) in a safe and convenient location for your records.

DETACH HERE: Fill out bottom portion completely and mail within 10 days of purchase/installation to:

▼ Sta-Rite, Attn: Warranty Dept., 293 Wright St., Delavan, WI 53115

STA-RITE®



Warranty Registration Card

Name _____

Years pool has been in service less than 1 1-3 3-5 5-10 _____

Address _____

Purchased from:
Company name _____

City _____ State _____ Zip _____

Address _____

Purchase Date _____

City _____ State _____ Zip _____

Product Purchased _____

New installation Replacement _____

Please send me more information on these other products from Sta-Rite.

Type of Pool Inground Vinyl Fiberglass Gunite _____

- Pumps Filters Automatic Pool Cleaners
- Maintenance Equipment Test Strips
- Heaters

Size of Pool _____

